

# 12V/3A DC-DC Buck Converter Module (LM2596)

# General Description

The 12V DC-DC Buck Converter Module is a compact and efficient power supply solution based on the LM2596 switching regulator. Designed as a direct drop-in replacement for the classic 7812 linear regulator, it offers a familiar pinout (IN, GND, OUT) while delivering much higher performance. With its ability to handle input voltages from 14V up to 40V, this module provides excellent flexibility for a wide range of applications.

Unlike traditional 7812 regulators that are limited to about 1A output current and often require large heatsinks to manage heat, this module can supply up to 3A continuous output current with conversion efficiency reaching 90%. This means less wasted energy, minimal heat dissipation, and no need for bulky cooling solutions, making it ideal for compact or battery-powered projects.

Thanks to its stable 12V regulated output, the module is perfectly suited for powering microcontrollers, development boards, sensors, and digital circuits. Its small form factor (23X19X15mm) makes it easy to integrate into DIY electronics, embedded systems, and industrial control applications where space and efficiency are critical.

**Direct 7812 Replacement:** Pin-compatible with standard 7812 linear regulator (IN, GND, OUT).

**High Current Output:** Supports up to 3A continuous load current, much higher than the 7812 (1A max).

**Wide Input Voltage Range:** Operates from 14V to 40V DC, offering greater flexibility compared to linear regulators.

**High Efficiency:** Up to 90% conversion efficiency, significantly reducing heat generation.

**Compact Size:** Miniature PCB design for easy integration in projects with limited space.

**Low Heat Dissipation:** Minimal power loss thanks to switching regulator technology, eliminating the need for bulky heatsinks.

**Stable Output:** Provides regulated 12V output suitable for powering microcontrollers, sensors, and other digital circuits.

**Dimensions(LXWXH):** 23X19X15mm





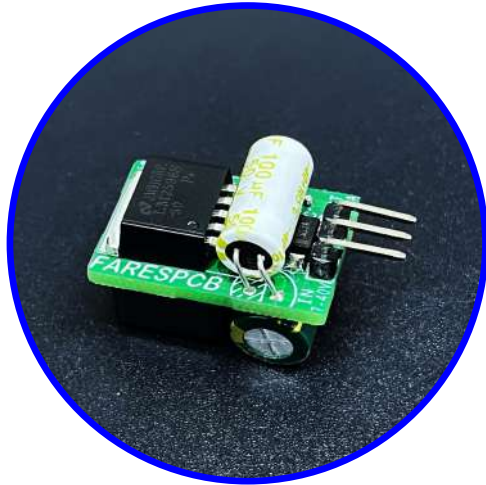

# Upgrade From Regulators to Buck Converters

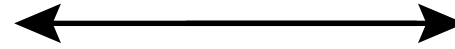





## 12V/3A DC-DC Buck Converter



## 7805 Linear Regulator (with Heatsink)



-  High efficiency (80–90% or more)
-  Runs cool under load
-  Wide input range (up to ~40V)
-  Output current Up to ~3A
-  Low dropout voltage (close to 0.5–2V)
-  Higher ripple (switching regulator)

-  Low efficiency (wastes excess voltage as heat)
-  Generates significant heat, requires heatsink
-  Narrow input range (needs ~8–20V)
-  Output current typically  $\leq 1\text{A}$  (limited by heat)
-  High dropout voltage (~3V)
-  Very low ripple (clean analog output)

# Pinout Description

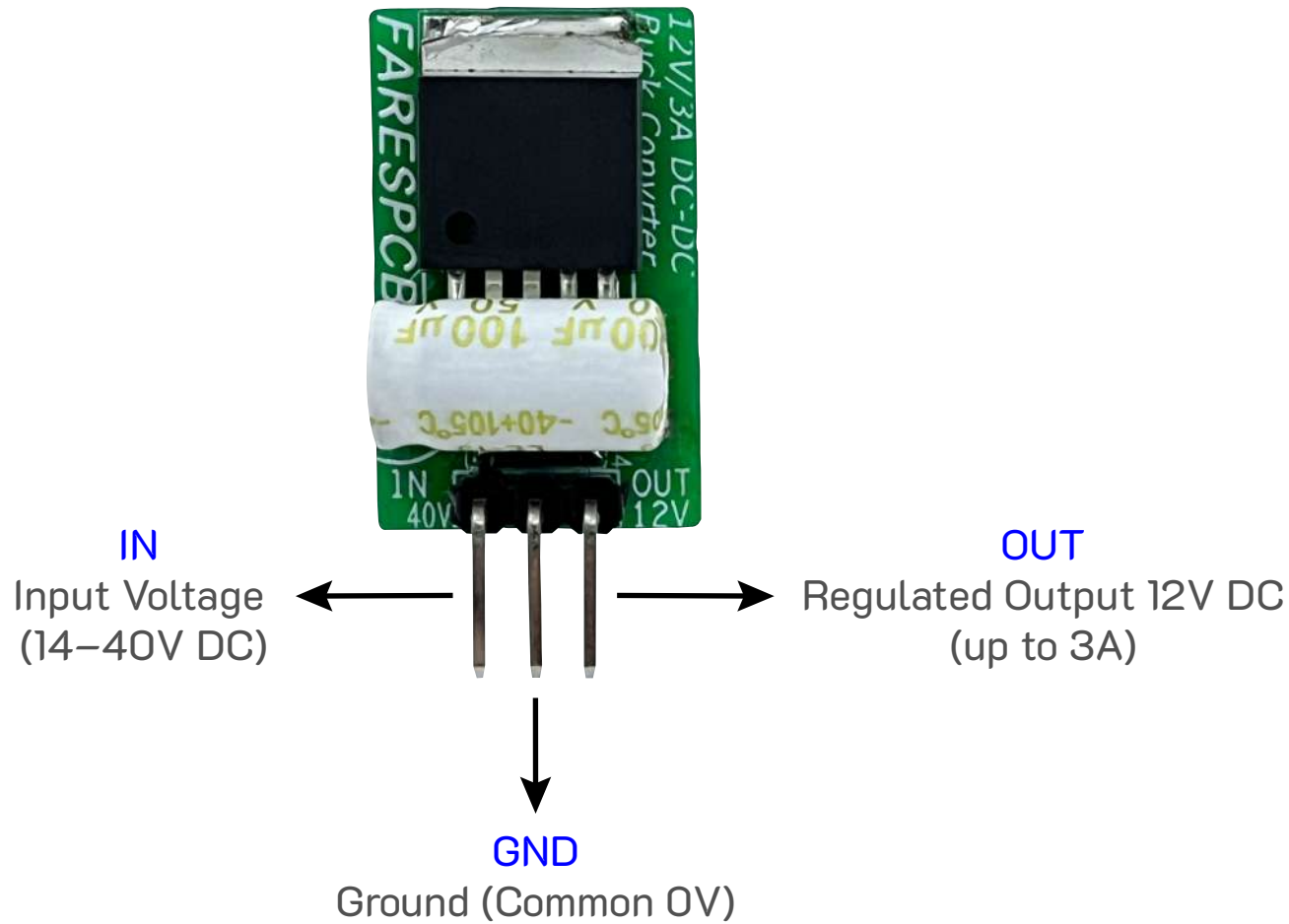

Connect IN to the DC supply (14–40V), GND as common ground, and OUT provides a stable 12V regulated output.

For our full range of products, see our website at <http://www.fares-pcb.com>

If you have any technical questions about our products,  
e-mail us at [www.support@fares-pcb.com](mailto:www.support@fares-pcb.com)

## **FARES<sup>PCB</sup> co. (Head office)**

32 El-Falaky st, Bab El-Louq, Tahrir, Cairo, Egypt.

Tel: +202-27901841

Mob: +201022457902

**FARES<sup>PCB</sup> Co** reserves the right to make changes in circuit design, software and/or specifications at any time without prior notice. For the latest updated information, please visit our website at <http://www.fares-pcb.com>.

Information furnished by is believed to be accurate and reliable. However, **FARES<sup>PCB</sup>** assumes no responsibility arising from the use of the specifications described.

### **Distributor:**

RAM Electronics

32 El Falaky St. Bab El Louk, Tahrir, Cairo, Egypt

Tel: +202-27960551

[www.ram.com.eg](http://www.ram.com.eg)

[Sales@ram-electronics.com](mailto:Sales@ram-electronics.com).

**RAM<sup>®</sup> Electronics**  
**INTEGRATED SOLUTIONS AT ONE PLACE**