

4-Channel Wireless Relay Module

General Description

The RM4N is a 4-channel wireless relay module based on the nRF24L01+ chip from Nordic Semiconductor. The nRF24L01 module is designed to operate in the global 2.4GHz ISM frequency band and uses GFSK modulation to transmit data. The card is well-protected, filtered, and easy to install. RM4N outputs can drive loads up to 10A (resistive loads).

Features

- Based on nRF24L01+ module.
- On-board 3.3V,5V regulator.
- Power input is filtered for noise reduction.
- LED for power indication.
- Operating voltage DC12V.
- Four output relays with red LED indicators.
- Both normal open and normal close terminals are available.
- Relay outputs are available through 5mm 2-pin K128 screw clamp terminals.
- Easy configuration and test.
- Reset push button switch is included.
- DIN Rail mountable.
- Four mounting holes for easy installation.



Board Details

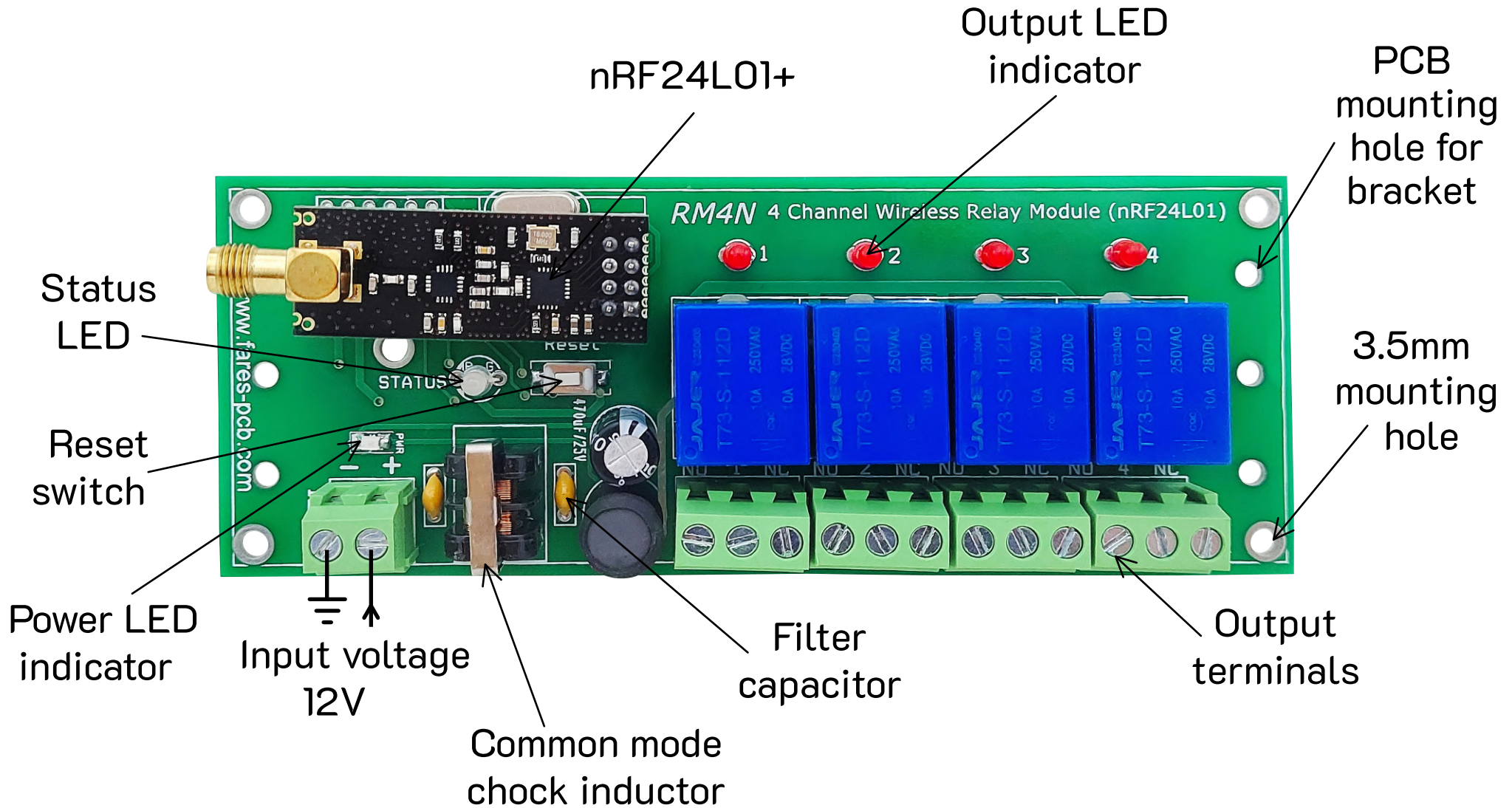

RM4N can be powered from a 12V DC power source. RM4N is protected from the reverse polarity of power. On-board DC EMI filter circuit is included to filter out high-frequency noise.

RM4N supports both nRF24L01+ and nRF24L01+ PA/LNA modules.

Bi-color LED (Green/Red) is included to indicate the different operating states.

Status LED action vs operation states is shown in the table below

Status LED Color	State	Description
Green	Ready	RM4N is ready for receiving commands
Red	Active	Transmitting/Receiving
Yellow	Reset request	Reset switch is pressed
Red flash	Reset executed	Reset operation is done

All node parameters can be reset to default values using the **RESET** switch. Press the **RESET** switch until the status LED is red flashing.

DIN Rail Mounting Options

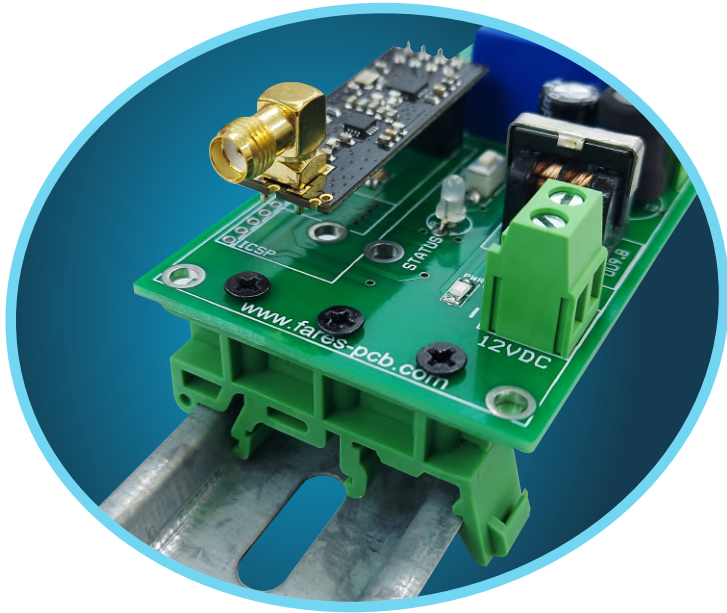

PCB Bracket

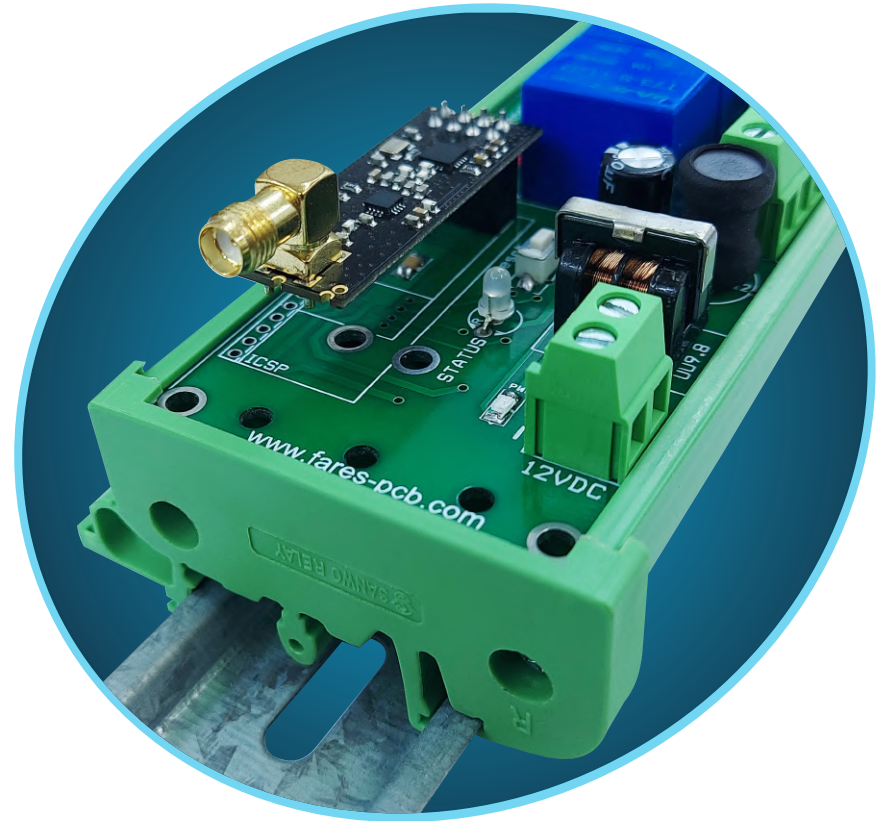

PCB Carrier

System overview

nRF wireless control system consists of three divisions

- Control device (such as PC or microcontroller).
- nRF master module which is a wireless serial-controlled module that can communicate to one or more nRF nodes.
- nRF I/O Node which is an I/O module that can control outputs and/or read inputs and can be communicated to an nRF master.



nRF I/O nodes can be controlled by an nRF master module in any micro-programmed system such as a PC, Arduino board, or microcontroller-based system. Each nRF node have a unique address and operate over a specific radio frequency band. The available addresses for nRF nodes are ranged from 1 to 64. All addresses can be reused over ten frequency channels (0-9). With a simple calculation, it can be concluded that each nRF master can control up to 640 I/O nRF nodes.

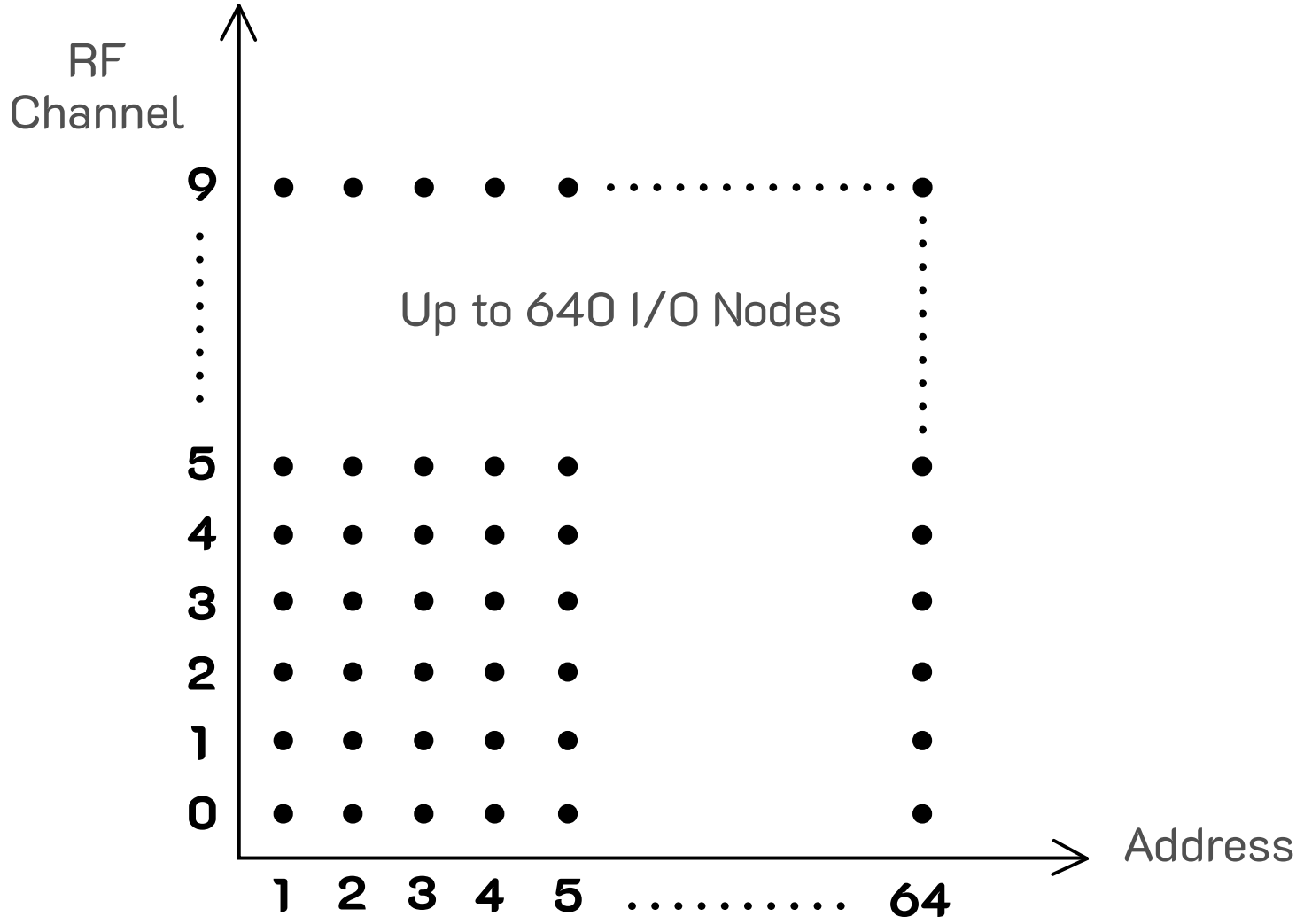

Address/RF Channel Distributing Chart

FARES PCB provides both USB-controlled and Serial-controlled nRF master modules as well. USB types A and B are available for flexibility. USB-controlled nRF master module is suitable for PC systems whereas serial-controlled module is more suitable for microcontroller-based systems. USB-controlled master module needs installing CH340 driver to be recognized. Communication baud rate is 115200 bps for both master types.

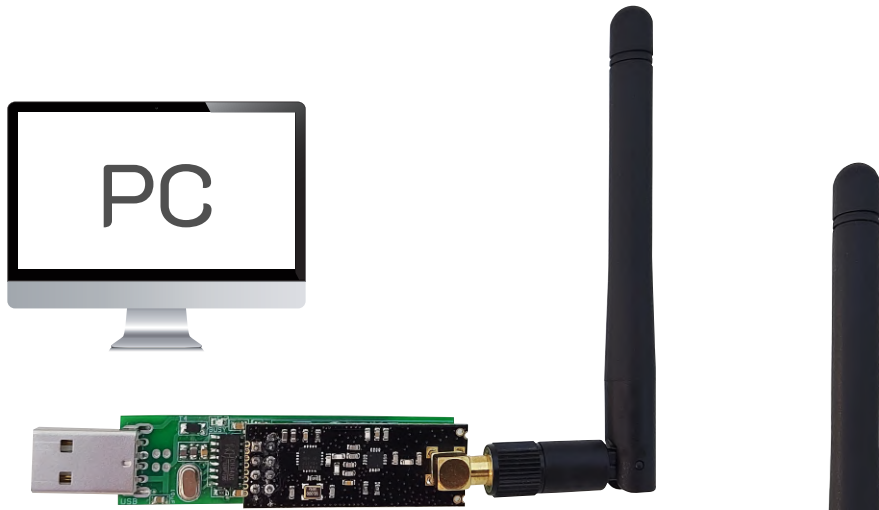

USB-controlled master (type A)

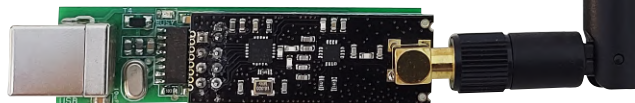

USB-controlled master (type B)

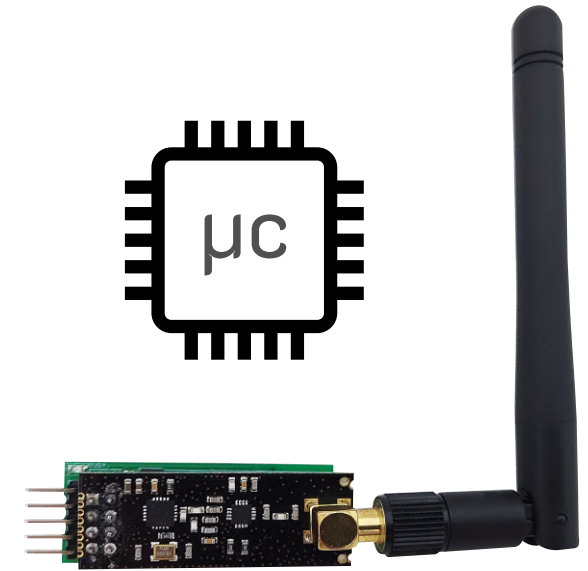

Serial-controlled master

FARES PCB provides a variety of I/O nRF nodes that vary according to the number of inputs and outputs. Some nodes contain only outputs, some contain only inputs, and some contain both.

Some of available nRF nodes

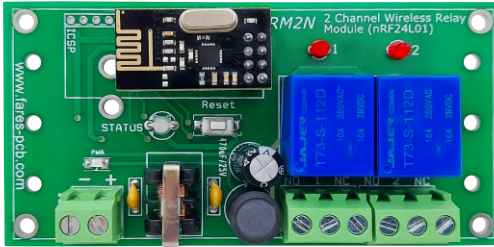

2-Channel Relay Module (nRF24L01)



4-Channel Relay Module (nRF24L01)



8-Channel Relay Module (nRF24L01)

Node Configuration

nRF Node Controller is a software developed by **FARES PCB** to configure and test nRF nodes.

nRF Node Controller program features:

- 1-Auto detects master module over USB ports.
- 2-Scan all available nRF nodes in range.
- 3-Set node address.
- 4-Set RF channel.
- 5-Test all I/Os of nRF nodes in range.
- 6-Apply commands to nRF nodes.

The screenshot shows the nRF node controller software interface. It features a dark blue background with white and orange text and buttons. The interface is divided into several sections:

- nRF master:** Includes a COM port dropdown (COM1) and a Detect button.
- Change Address/RF Channel:** Contains fields for Current Address (01), New Address (01), Current RF Ch (0), and New RF Ch (0), each with an Update button.
- Test channel commands:** Includes fields for Address (01), RF Channel (0), and I/O Channel (01), with a Check node button.
- Output:** Features ON, OFF, and Toggle buttons, and a Read button.
- Input:** Features a Read button.
- Node Control Commands:** A table with columns for Address, RF Ch, Command, and I/O Ch. The Command field is highlighted with a red circle and contains the text "010N01". Below the table is a text box with the command: "Turn on output <01> at address <01> and RF channel <0>".
- Scan Nodes:** A large empty text area for displaying scan results.
- Scan RF Channel:** A dropdown menu set to 0, with Start and Stop buttons.
- Terminal:** A text area showing communication logs: "PC: Search COM1...", "PC: NRF01+", and "Master: OK". It includes a Send button and a Clear button at the bottom.

Numbered callouts (1-14) point to various elements: 1 points to the COM1 dropdown; 2 points to the New Address field; 3 points to the Check node button; 4 points to the ON button; 5 points to the Read button in the Output section; 6 points to the Read button in the Input section; 7 points to the Command field in the Node Control Commands table; 8 points to the FARES PCB logo; 9 points to the Scan Nodes text area; 10 points to the Scan RF Channel dropdown; 11 points to the Start button; 12 points to the Stop button; 13 points to the Send button; 14 points to the Clear button.

- 1 - Auto detect master over all USB ports.
- 2 - Get node information.
- 3 - Turn off selected output channel.
- 4 - Turn on selected output channel.
- 5 - Read selected output channel.
- 6 - Read selected input channel.
- 7 - Click to send command.
- 8 - Change to new address.
- 9 - Change to new RF channel.
- 10 - Reverse status of selected output channel.
- 11 - Start searching for all available nodes.
- 12 - Stop searching for all available nodes.
- 13 - Send text.
- 14 - Clear terminal contents.

How to configure new nRF I/O node module

In a large-scale nRF wireless control system, each nRF node must have a unique address within the same RF band. nRF node comes pre-configured to the default address and RF channel. The default address is 01 and the default RF channel is 0.



nRF node address and RF channel can be reset to default values by pressing **Reset** button and holding it for 5 seconds.

To assign a new address and/or RF channel to nRF node using nRF node Controller software follow the next steps:

- 1 – Plug the nRF master module into the PC.
- 2 – Connect nRF node to 12VDC power source.
- 3 – Open nRF node controller software. The program will automatically start searching master module over all available USB ports.

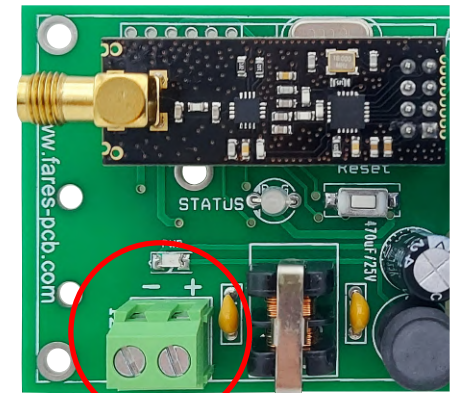

12V

the results of search process are shown in the terminal window. If it fails to detect a master module try to click **Detect** button.

The screenshot shows the nRF node controller software interface. The 'nRF master' section at the top left has a dropdown menu set to 'COM1' and a 'Detect' button, both highlighted with orange boxes and callouts. Below this is the 'Change Address/RF Channel' section with fields for 'Current Address' (01), 'New Address' (01), 'Current RF Ch' (0), and 'New RF Ch' (0), each with an 'Update' button. The 'Test channel commands' section includes fields for 'Address' (01), 'RF Channel' (0), and 'I/O Channel' (01), with a 'Check node' button. The 'Output' section has 'ON', 'OFF', and 'Toggle' buttons, and a 'Read' button. The 'Input' section has a 'Read' button. The 'Node Control Commands' section has a table with columns 'Address', 'RF Ch', 'Command', and 'I/O Ch', and a text area with the command 'Turn on output <01> at address <01> and RF channel <0>'. On the right side, the 'Scan Nodes' section has a 'Scan RF Channel' dropdown (0) and 'Start' and 'Stop' buttons. The 'Terminal' window at the bottom right is highlighted with an orange box and callout, showing the text: 'PC: Search COM1...', 'PC: NRF01+', and 'Master: OK'. The FARES PCB logo and 'For Electronic Solutions' tagline are visible in the top right corner.

4 – Select the current address of nRF node (01 for fresh node) and select the required new address (range from 01 to 64).

5 – Click **Update** button. The result of address changing is shown in the terminal window.

The screenshot shows the 'nRF node controller' software interface. The window title is 'nRF node controller'. The interface is divided into several sections:

- nRF master:** Includes a dropdown menu for 'COM1' and a 'Detect' button.
- Change Address/RF Channel:** This section contains two rows of controls. The first row has 'Current Address' (dropdown '01'), 'New Address' (dropdown '01'), and an 'Update' button. The second row has 'Current RF Ch' (dropdown '0'), 'New RF Ch' (dropdown '0'), and an 'Update' button. A callout 'Update button' points to the 'Update' button in the first row.
- Test channel commands:** Includes 'Address' (dropdown '01') and 'RF Channel' (dropdown '0'). There is a 'Check node' button and an 'I/O Channel' dropdown set to '01'.
- Output:** Features 'ON', 'OFF', and 'Toggle' buttons, and a 'Read' button.
- Input:** Features a 'Read' button.
- Node Control Commands:** Includes a table with columns 'Address', 'RF Ch', 'Command', and 'I/O Ch'. The table contains one row: '01', '0', 'N', '01', '010N01'. Below the table is a text field with the command: 'Turn on output <01> at address <01> and RF channel <0>'. There is also a 'Clear' button.
- Scan Nodes:** A large empty text area for displaying scan results.
- Scan RF Channel:** A dropdown menu set to '0', with 'Start' and 'Stop' buttons.
- Terminal:** A text area showing the output: 'PC: Search COM1...', 'PC: NRF01+', and 'Master: OK'. A 'Send' button is above it, and a 'Clear' button is below it. A callout 'Terminal window' points to this section.

Callouts in the image:

- 'Current Address' points to the 'Current Address' dropdown.
- 'New Address' points to the 'New Address' dropdown.
- 'Update button' points to the 'Update' button in the 'Change Address/RF Channel' section.
- 'Terminal window' points to the terminal output area.

6 – Repeat Steps 4-5 to change the RF channel of nRF node.

To get node access information for an unknown node follow the next steps

- 1 – Plug the nRF master module into the PC.
- 2 – Connect unknown nRF node to 12VDC power source.
- 3 – Select scan RF channel number 0.
- 4 – Click **Start** button to start scanning for all available nRF node addresses in 0 RF channel band.
- 5 – Detected node addresses will appear in the scan window.
- 6 – If no nodes are detected repeat steps 3-5 for the next RF channel.

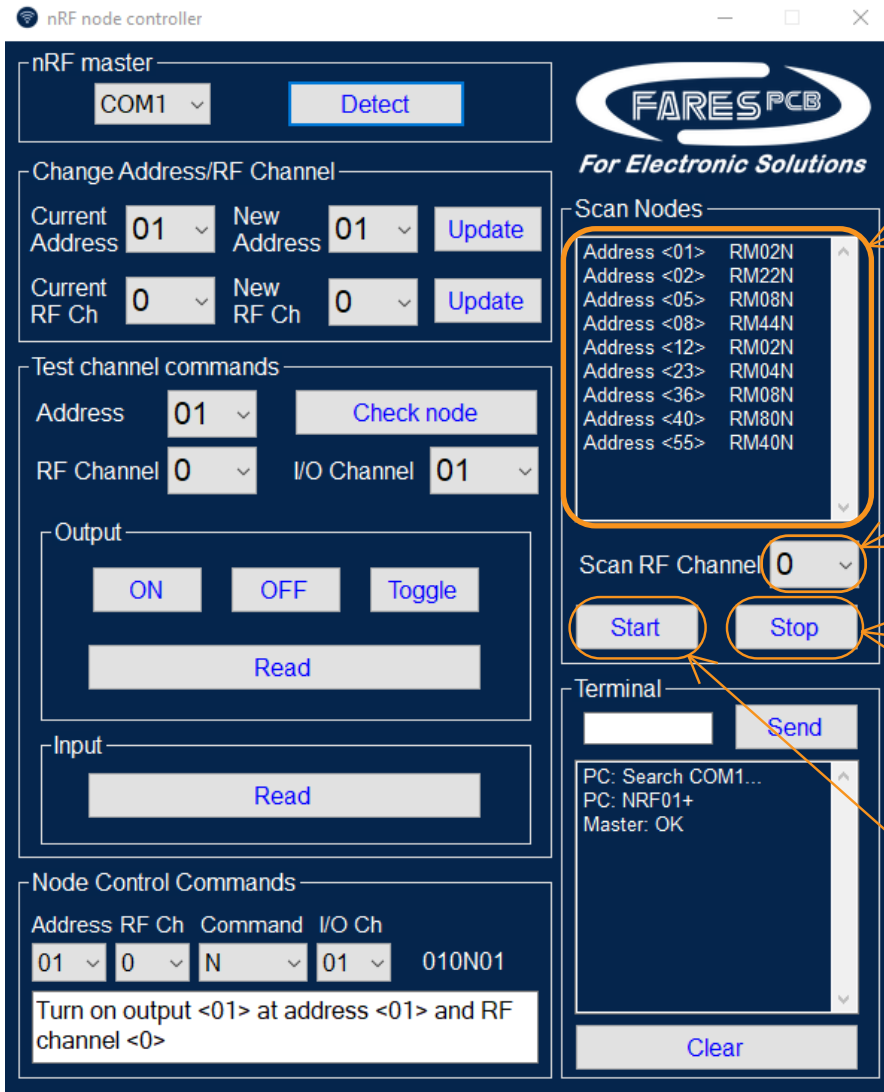

Scan window

RF channel to be scanned

Start scan operation

Stop scan operation

Mechanical Dimensions Diagram

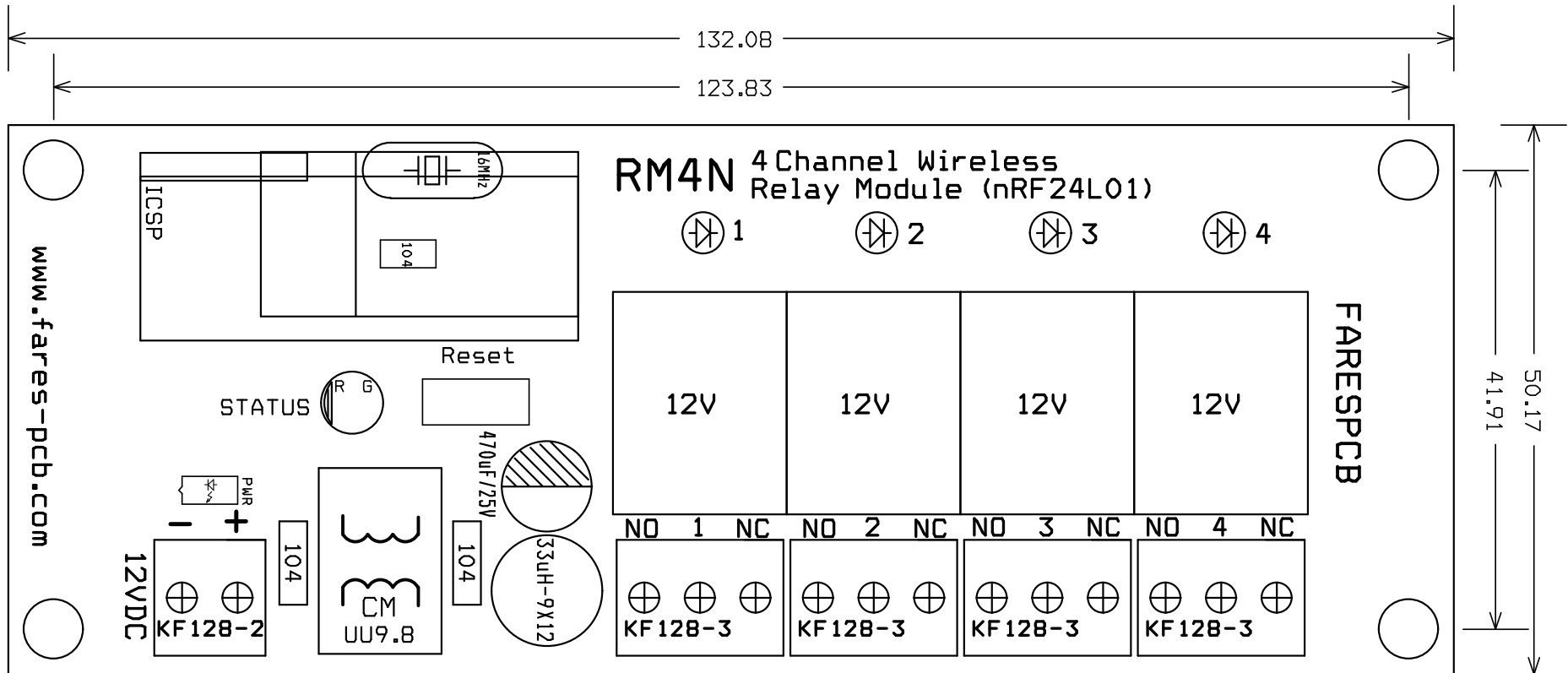

All dimensions are in mm

For our full range of products, see our website at <http://www.fares-pcb.com>

If you have any technical questions about our products,
e-mail us at www.support@fares-pcb.com

FARES^{PCB} co. (Head office)

32 El-Falaky st, Bab El-Louq, Tahrir, Cairo, Egypt.

Tel: +202-27901841

Mob: +201022457902

FARES^{PCB} Co reserves the right to make changes in circuit design, software and/or specifications at any time without prior notice. For the latest updated information, please visit our website at <http://www.fares-pcb.com>.

Information furnished by is believed to be accurate and reliable. However, **FARES^{PCB}** assumes no responsibility arising from the use of the specifications described.

Distributor:

RAM Electronics

32 El Falaky St. Bab El Louq, Tahrir, Cairo, Egypt

Tel: +202-27960551

www.ram.com.eg

Sales@ram-electronics.com.

RAM[®] Electronics
INTEGRATED SOLUTIONS AT ONE PLACE